

CHIPREG MFC

Mass Flow Controller

- Ultra compact size < 22mm
- High turndown ratio
- Best performance-to-cost ratio
- Fast time-to-market through complete sub-assemblies
- Analytical clean version available
- No drift, no recalibration required
- For bioreactors, analytical, medical devices and process control applications

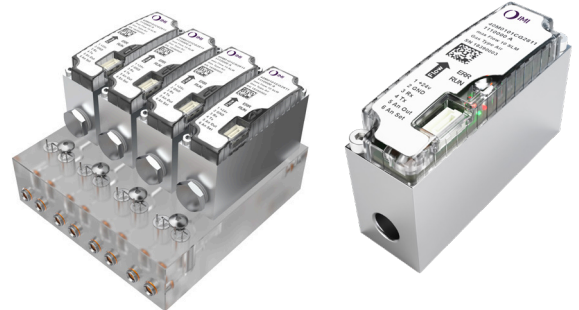

Technical features

Sensor:
Thermal MFC sensor

Flow ranges:

0-0,2 l_s/min
0-0,5 l_s/min
0-1 l_s/min
0-2 l_s/min
0-5 l_s/min
0-10 l_s/min
0-20 l_s/min

On request:

Lower flows (down to 0-1 ml/min)
Higher flows (up to 0-150 l/min)

Standard conditions:

P=1013 mbar (1 atm), T=20°C

Operating gas:

Air, N₂, O₂, CO₂, Ar, neutral gas*
Multigas, He/H₂ on request

Accuracy*:

± 0,2% of full scale (0-10% of max flow)
± 2,0% of reading (10%-100% of max flow)

Repeatability:
< 1% of reading

Operating voltage:
24 V d.c. ± 10%

Current supply:
< 100 mA

Electrical connection:
JST Connector BM06B-GHS-TBT

Analog input/output control:
0 ... 5 V d.c.

Pneumatic connections:
In line version (G1/8")
Manifold mount

Weight:
125g

Digital communication interfaces:
RS232
RS485
Other interfaces on request

Digital communication protocol:
IMI FAS proprietary protocol &
Modbus RTU

Seal material:
FPM
USP class VI seals on request

Gas temperature:
+10 ... +50°C (*50 ... +122°F)

Ambient temperature:
+10 ... +50°C (*50 ... +122°F)

Dynamic range:
Standard: 500:1
Premium: 1000:1

Response time:**
As fast as 100 ms
No warm-up time

Thermal drift:
± 0,004% of full scale per °C (0-10% of max flow)
± 0,04% of reading per °C (10-100% of max flow)

Additional options:
USP class VI seals, stainless steel manifold for bioreactors

* MFC are calibrated with air at 5 barg inlet, 0 barg outlet, 20 °C. Accuracy does not include reference error. Conversion factors (k-factors) are applied for other gas. See gas flow equivalency table for more information.

** From 0 to 90% of flow, at calibration condition. Up to 500 ms depending on conditions.

Technical data – standard models

Flow range (l _v /min)	Max. operating pressure (bar)	Port type	Digital Communication Interface	kv *1)	Model
0 ... 0,2	8	G 1/8	RS485	0,02	40M2002CJ2811 1110000
0 ... 0,5	8	G 1/8	RS485	0,02	40M5002CJ2811 1110000
0 ... 1	8	G 1/8	RS485	0,02	40M0011CJ2811 1110000
0 ... 2	5	G 1/8	RS485	0,12	40M0021CJ2811 1110000
0 ... 5	5	G 1/8	RS485	0,12	40M0051CJ2811 1110000
0 ... 10	5	G 1/8	RS485	0,12	40M0101CJ2811 1110000
0 ... 20	4	G 1/8	RS485	0,55	40M0201CJ2811 2110000

*1) Cv = 0,07 kv

Starter kit (optional)

- USB hub connector, with possibility to plug up to 3 devices in RS485
- 3x electrical cables with JST connections
- Power supply, universal input voltage range and interchangeable AC blades for global use

S401.0312A

Electrical connection (optional)

Electrical connector
JST GHR-06V-S
with 300 mm flying leads



S401.0024

Codification and option selector

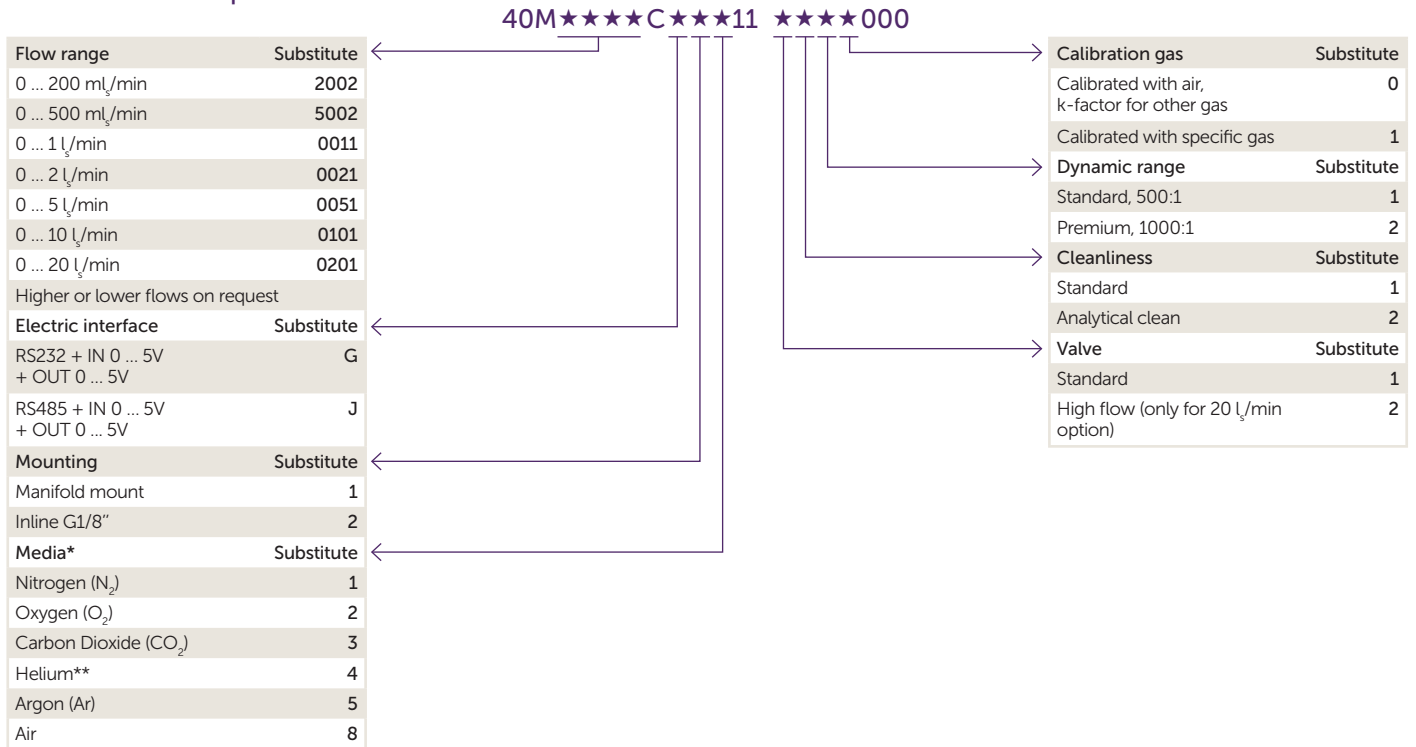

* See gas flow equivalency table below
 ** On demand

Gas flow equivalency table – flow range

Units	Air flow range	N ₂ flow range	O ₂ flow range	CO ₂ flow range	Ar flow range
(ml _v /min)	200	200	200	100	187
(ml _v /min)	500	500	500	236	446
(l _v /min)	1	1	1	0,532	0,892
(l _v /min)	2	2	2	0,970	1,78
(l _v /min)	5	5	5	2,43	4,46
(l _v /min)	10	10	10	4,93	8,06
(l _v /min)	20	20	20	9,72	15,9
Additional accuracy error when calibrated with air		0	0	± 8% of reading	± 8% of reading

This table shows the flow range and accuracy of multiple gas when using a MFC calibrated with air. For more specific flow ranges, or for better accuracy, calibration with process gas can be performed, see product codification and option selector.

When switching from one gas to another in a single MFC, it is common practice to ensure the system is fully flushed with new gas before starting precise control.

Maximum Flow Rate

Flow rate may be limited by inlet pressure.

Please ensure your inlet pressure is high enough to achieve your desired maximum flow rate as per below curves.

Typical data for air at 20°C

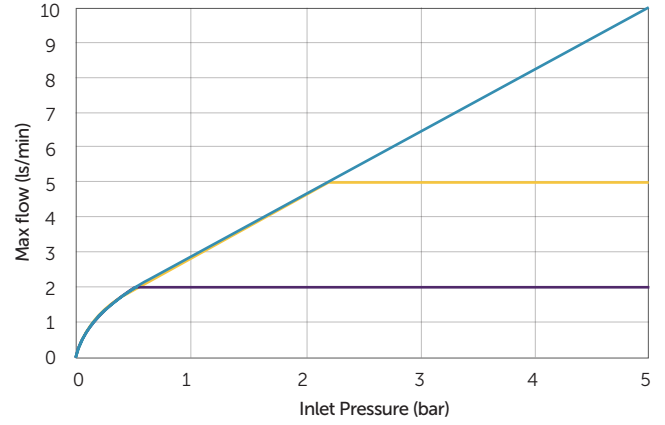
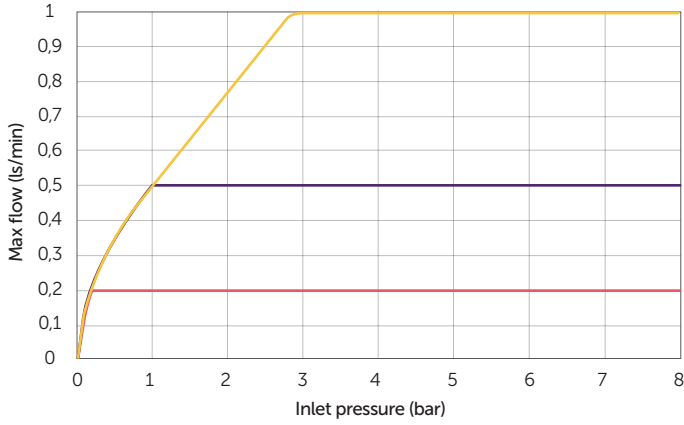

— CHIPREG 200 ml/min — CHIPREG 500 ml/min — CHIPREG 1 l/min — CHIPREG 2 l/min — CHIPREG 5 l/min — CHIPREG 10 l/min

Typical data for air at 20°C

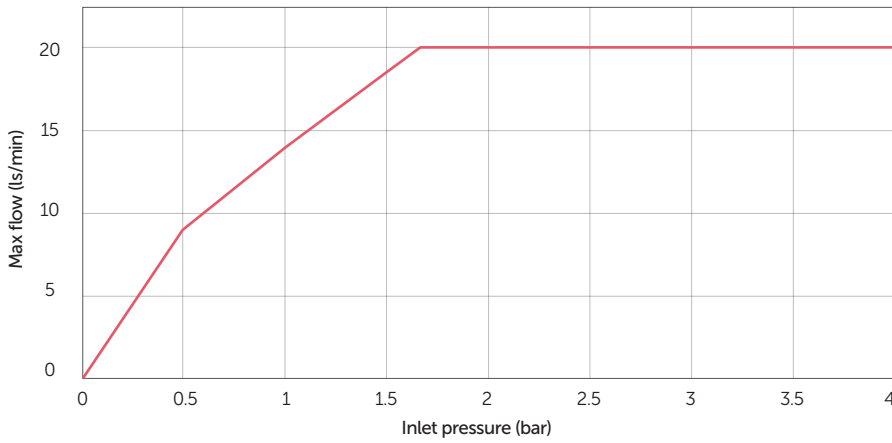

— CHIPREG 20 l/min

Block diagram

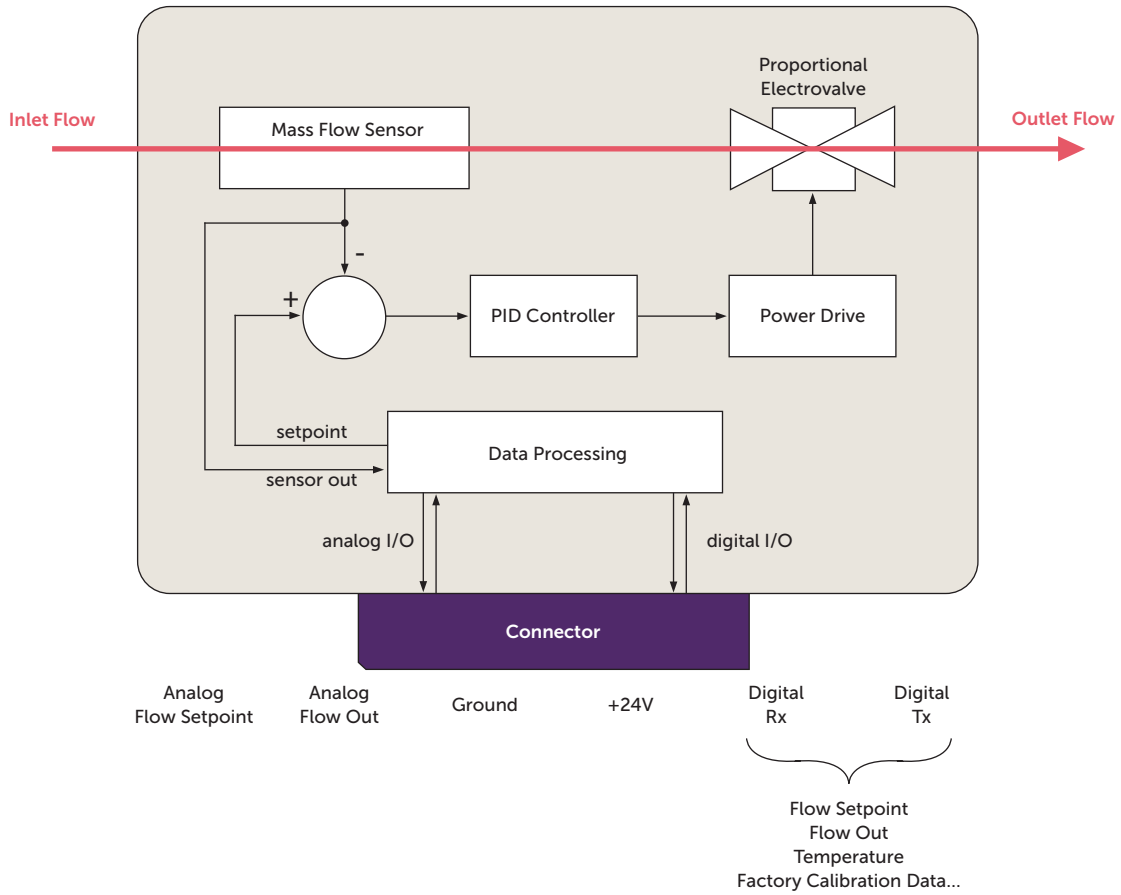

Dimensions

Manifold mount

Dimensions in mm
Projection/first angle

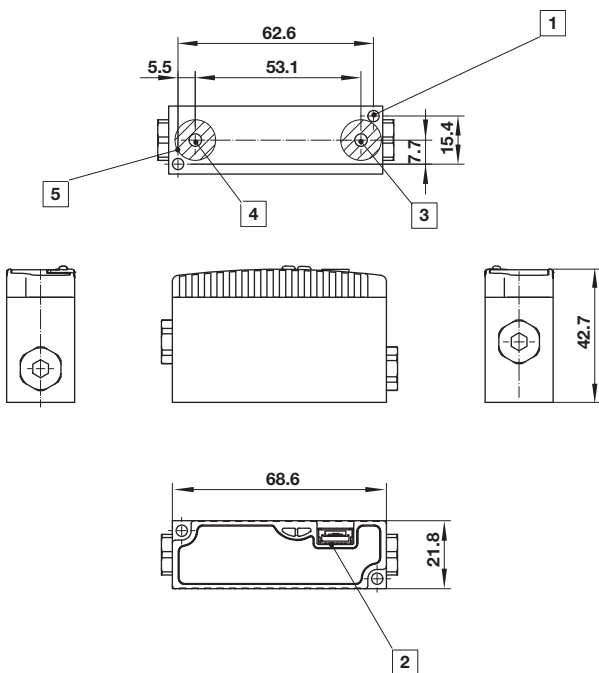

- 1 \varnothing 3,6 mm through hole (2x)
- 2 Connector JST BM06B-GHS-TBT (First pin on the left)
- 3 INLET \varnothing 4 mm
- 4 OUTLET \varnothing 4 mm
- 5 \varnothing 13 (2x) sealing area /Ra 0,8

Electrical connection

Pin#	Description (RS232)	Description (RS485)
1	+24V	+24V
2	Ground	Ground
3	Rx	A
4	Tx	B
5	Analog flow out	Analog flow out
6	Analog flow setpoint	Analog flow setpoint

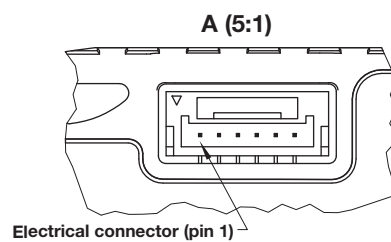

Dimensions

Inline version (G1/8")

Dimensions in mm
Projection/first angle

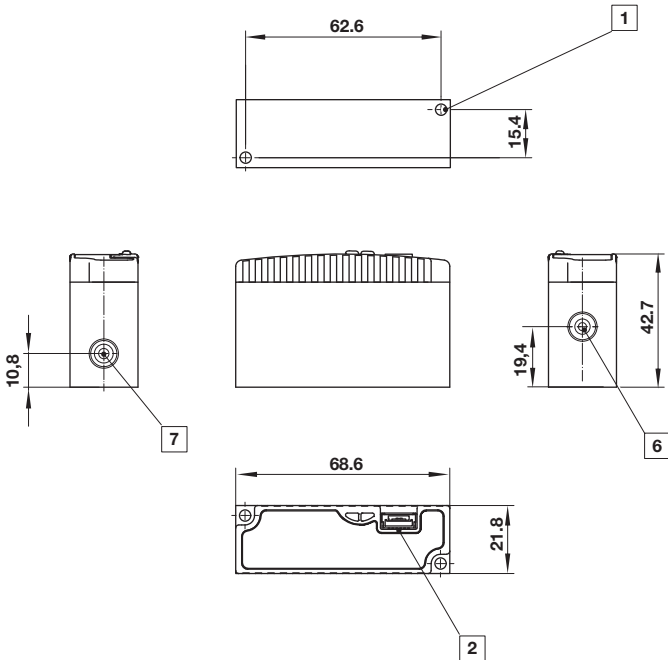

- 1 \varnothing 3,6 mm through hole (2x)
- 2 Connector JST BM06B-GHS-TBT (First pin on the left)
- 6 OUTLET G1/8" Thread depth 9 mm
- 7 INLET G1/8" Thread depth 9 mm

Electrical connection

Pin#	Description (RS232)	Description (RS485)
1	+24V	+24V
2	Ground	Ground
3	Rx	A
4	Tx	B
5	Analog flow out	Analog flow out
6	Analog flow setpoint	Analog flow setpoint

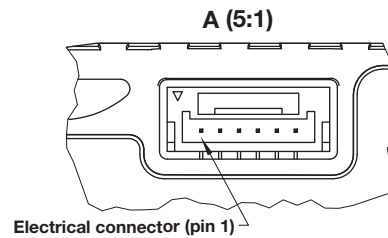

Warning

These products are intended for use with aggressive sensitive media, Please contact FAS MEDIC SA for more compatibility requests. Do not use these products where pressures and temperatures can exceed those listed under „**Technical features/data**“. Before using these products with fluids other than those specified, for non-industrial applications, life-support systems or other applications not within published specifications, consult FAS MEDIC SA.

Through misuse, age, or malfunction, components used in fluid power systems can fail in various modes.

The system designer is warned to consider the failure modes of all component parts used in fluid power systems and to provide adequate safeguards to prevent personal injury or damage to equipment in the event of such failure. System designers must provide a warning to end users in the system instructional manual if protection against a failure mode cannot be adequately provided.

System designers and end users are cautioned to review specific warnings found in instruction sheets packed and shipped with these products.