

# 6,5 mm FLEXISOL

## Direct acting 2-way and 3-way valves

- Flow of a 8 mm valve in a 6,5 mm footprint, without usual manufacturing constraints
- One-screw mount
- Solder free / direct connection on PCB
- Captive seals



### Technical features

**Medium:**

Air, oxygen, neutral gases, 40 µm filtered

**Operation:**

Direct acting 2-way and 3-way valves, normally closed and normally opened

**Operating pressure:**

0 ... 2,5 bar

**Flow:**

See technical data - standard models

**Leakage:**

Internal leakage: 10-2 mbar l/s  
External leakage: 10-2 mbar l/s

**Mounting:**

Manifold with M3 mounting screw

**Orifice:**

See technical data – standard models

**Life expectancy:**

50'000'000 cycles

**Response time:**

Pneumatic response time (ON): 5 ms  
Pneumatic response time (OFF): 10 ms  
Response time measured according to ISO 12238

**Weight:**

8 g

**Ambient/Media temperature:**

0° ... +50°C (+32° ... +122°F)

**Materials in contact with the fluid:**

Body: PPS  
Seals: NBR, FPM  
Internal parts: stainless steel, HNBR, FPM

### Electrical details

Voltage	24 V d.c.
Duty cycle	100% ED
Voltage tolerance	± 5%
Power consumption	0,8 W
Protection class	IP51
Insulation class	E180
Electrical connection	PAD (0,4 µm galvanic gold over nickel)

### Following options on request

Pneumatic connection
Electrical connection
Mounting screw
Coil orientation
Other voltages (5V, 3V)

### Electrical insulation:

The plastic body and the mechanical fixation system of the valve withstand more than 500 V test voltage. For safety isolation, the metallic parts of the valves (excluding parts used for valve's fixation) are formally not isolated from the valve power supply and proper distances and considerations need to be taken at system level.

**Note 1:** Applicable standards do not allow to consider the copper-wire varnish as an insulation barrier.

**Note 2:** A minimum distance 0,05 mm is required between the magnetic circuit of the valve and any metal part, and between two circuits when the valves are in battery.



### FLEXISOL, Flange and Flying leads (B01)

Dimensions in mm  
Projection/first angle

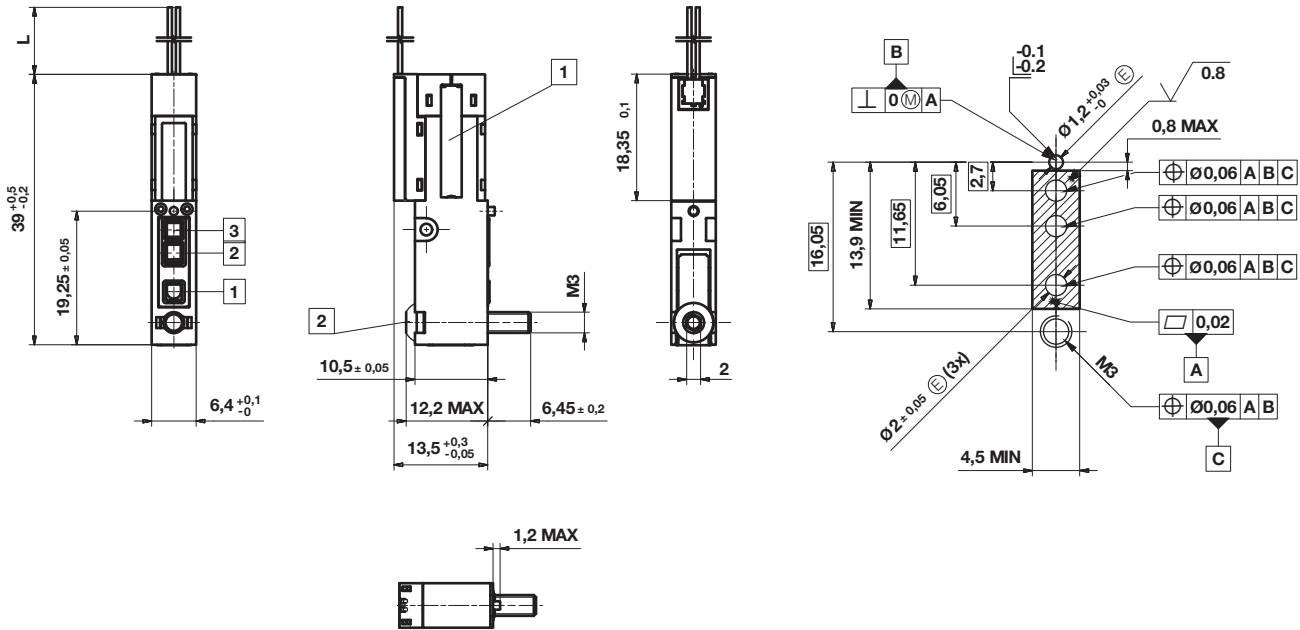

- 1 Metallic part
- 2 Fixing screw M3 x 16 tightening torque  $0,3 \pm 0,05$  Nm

### FLEXISOL, Barb Fittings and Flying leads (B03)

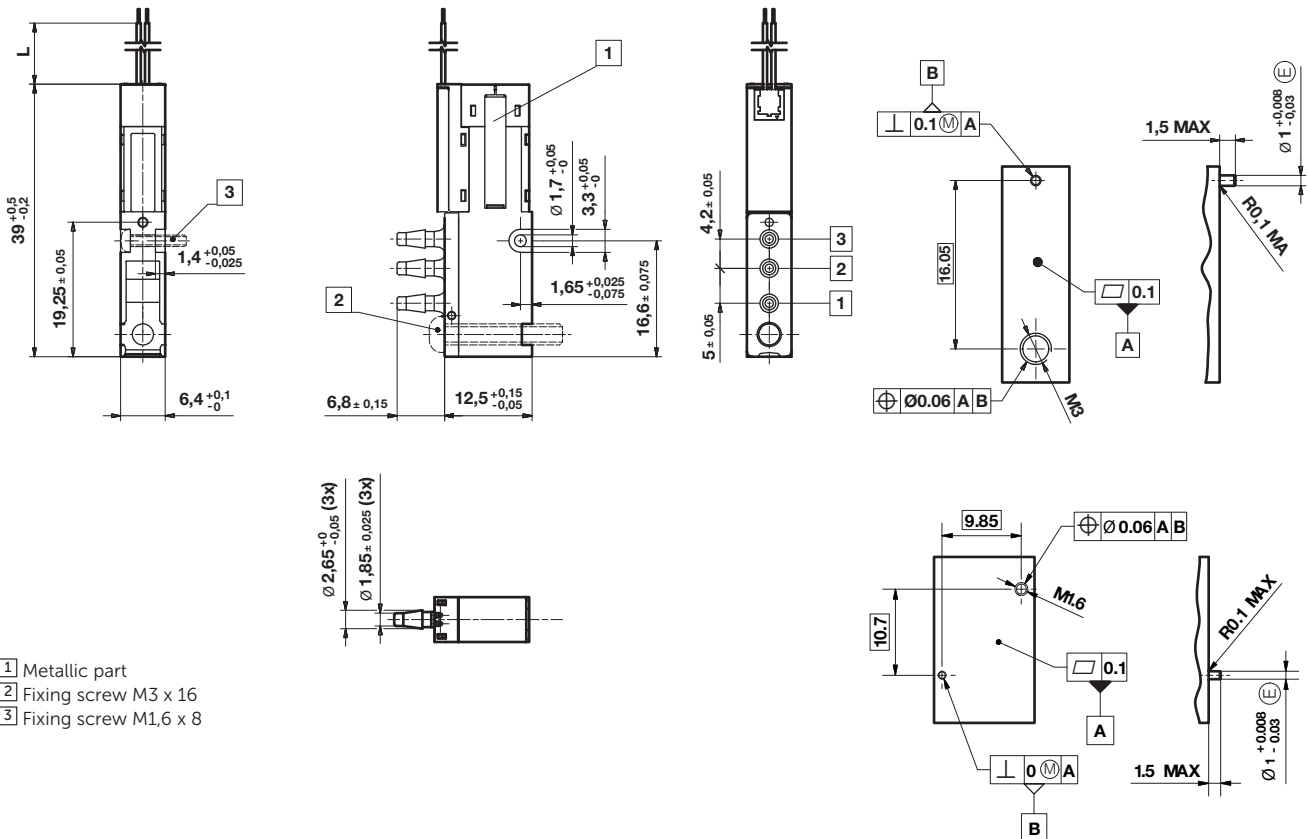

- 1 Metallic part
- 2 Fixing screw M3 x 16
- 3 Fixing screw M1,6 x 8

### FLEXISOL Test Sub-base Pads version S151.0013

Dimensions in mm  
Projection/first angle

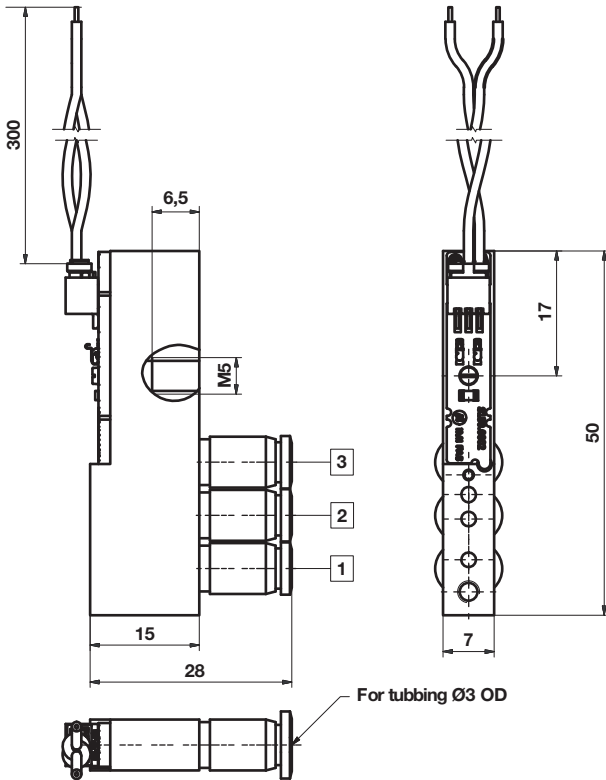

### FLEXISOL Test Sub-Base Flying Leads version S151.0034

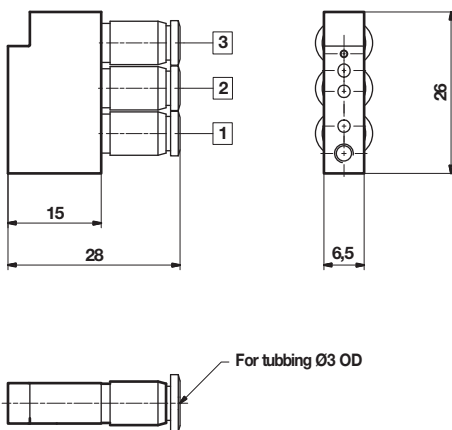

#### Warning

These products are intended for use in air, oxygen and neutral gas systems only. Do not use these products where pressures and temperatures can exceed those listed under »**Technical features**«.

Before using these products with fluids other than those specified, for non-industrial applications, life-support systems, or other applications not within published specifications, consult IMI Plc., FAS MEDIC SA.

Through misuse, age, or malfunction, components used in fluid power systems can fail in various modes.

The system designer is warned to consider the failure modes of all component parts used in fluid power systems and to provide adequate safeguards to prevent personal injury or damage to equipment in the event of such failure.

System designers must provide a warning to end users in the system instructional manual if protection against a failure mode cannot be adequately provided.

System designers and end users are cautioned to review specific warnings found in instruction sheets packed and shipped with these products.