

# 16 mm FLATPROP EQP

## High flow pressure compensated proportional valve



- 2/2 NC pressure compensated proportional valve
- High flow, high precision
- Increased flow - 200 l/min of air at 2,4 bar
- Low power consumption of 2,5 W
- Frictionless design enables high resolution

### Technical features

**Medium:**  
Air, oxygen or neutral gases

**Orifice:**  
4,6 mm

**Filtration:**  
A filtration of 20 micrometer is required before the inlet

**Operation:**  
2-way valve, Normally closed

**Hysteresis:**  
See diagrams on page 2

**Flow:**  
> 200 l/min at 2,4 bar

**Operating pressure:**  
0 ... 7 bar (0 ... 101 psi)

**Back pressure:**  
Maximum 10% of inlet pressure

**Mounting:**  
Cartridge

**Size:**  
16 mm

**Life expectancy:**  
≥ 100 Mio. cycles (with triangular signal)

**Internal leakage:**  
< 10-2 mbar l/s (≈0,6 ml/min)  
0 ... pmax

**External leakage:**  
< 10-2 mbar l/s (≈0,6 ml/min)  
p = 9,5 bar

**Weight:**  
< 50 g (0,11 lbs)

**Ambient/media temperature:**  
+10 ... +50°C (+50 ... +122°F)

**Materials:**  
Body: Stainless steel only or stainless steel/brass  
Seal: FPM, NBR

**Manifolds:**  
Contact your local fluid control specialist for information about our manifolding capabilities which include laminated polymer manifolds.

### Electrical details

Voltage/frequency	See technical data -standard coils
Power consumption	2,5 W nominal at T=20°C
Insulation class	F (155°C)
Electrical insulation	1000 V a.c.
Protection degree	IP51
Duty cycle	100%
Electrical connection	300 mm A WG24 flying leads

### Following options on request

Range of drive current
Higher temperature range
Manifold mount adaptor
EPDM seals
OEM specification

### Technical data – standard models

Symbol	Current (mA)	Resistance (Ω)	Body Material	Seal Material	Model
	104	230	Stainless steel/Brass	FPM	12-216C-04621+EQPFIL+BDU
	211	57	Stainless steel/Brass	FPM	12-216C-04621+EQPFIL+BED
	417	14,4	Stainless steel/Brass	FPM	12-216C-04621+EQPFIL+BEK
	104	230	Stainless steel/Brass	NBR	12-216C-04620+EQPFIL+BDU
	211	57	Stainless steel/Brass	NBR	12-216C-04620+EQPFIL+BED
	417	14,4	Stainless steel/Brass	NBR	12-216C-04620+EQPFIL+BEK
	104	230	Stainless steel	FPM	12-216C-04641+EQPFIL+BDU
	211	57	Stainless steel	FPM	12-216C-04641+EQPFIL+BED
	417	14,4	Stainless steel	FPM	12-216C-04641+EQPFIL+BEK
	104	230	Stainless steel	NBR	12-216C-04640+EQPFIL+BDU
	211	57	Stainless steel	NBR	12-216C-04640+EQPFIL+BED
	417	14,4	Stainless steel	NBR	12-216C-04640+EQPFIL+BEK

### Technical data – standard coils

Valve orifice (mm)	Coil resistance at 20°C (+68°F) ± 3% [R20] (Ω)	Current for maximum flow [nominal] (mA)	Voltage +20°C (+68°F) [nominal] (V)	Power +20°C (+68°F) [nominal] (W)	Max. required voltage for max flow *1) (V)
4,6	14,4	417	6	2,5	9
	57	211	12	2,5	18
	230	104	24	2,5	36

\*1) Please refer to instruction K12M.0001 for recommendation on drive signals

### Additional information

#### Typical flows vs. supply pressure Air, 20°C, without back pressure

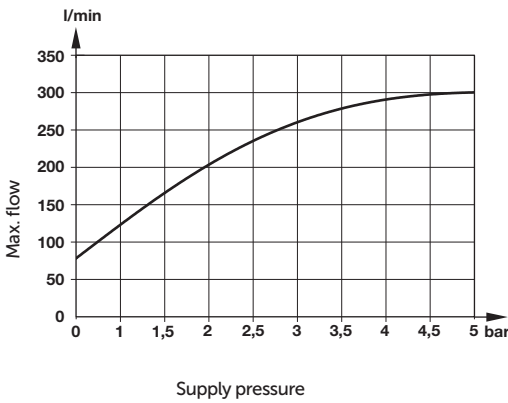

#### Typical hysteresis curves Air, 20°C, without back pressure

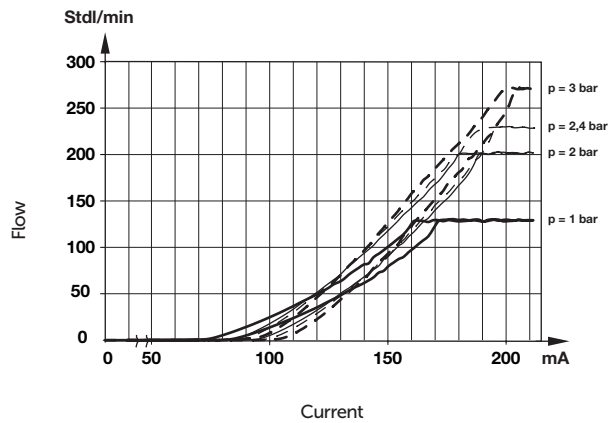

#### Note:

Flow vs. supply pressure curves are for informative purposes only and shall be used only for the pre-selection of the orifice size. Preliminary testing is recommended to take into account all application specific requirements and to select the most adequate orifice.

For further information contact your local fluidic specialist.

### Accessories

Manifold for cartridge version with G1/4 ports in aluminium



Page 3

S120.0152

# FLATPROP EQP cartridge mounting

Dimensions in mm  
Projection/first angle

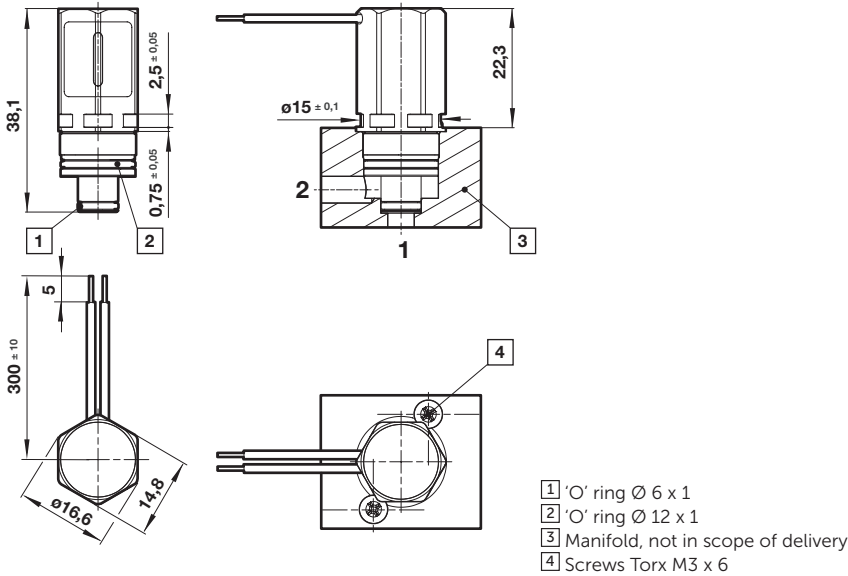

## Cartridge fitting D120.0010

## Test manifold S120.0152

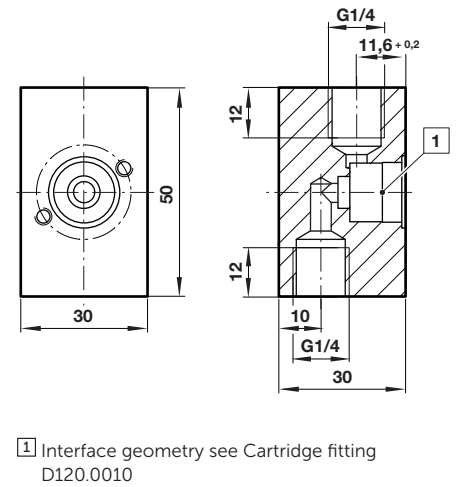
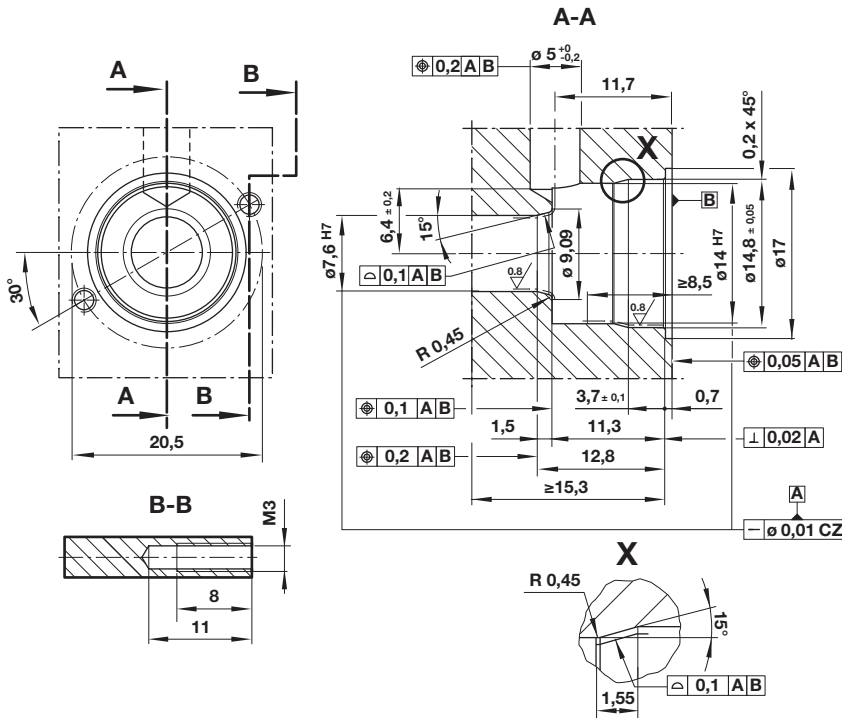

### Warning

These products are intended for use in air, oxygen and neutral gas systems only. Do not use these products where pressures and temperatures can exceed those listed under »**Technical features**«.

Before using these products with fluids other than those specified, for non-industrial applications, life-support systems, or other applications not within published specifications, consult IMI Plc., FAS MEDIC SA.

Through misuse, age, or malfunction, components used in fluid power systems can fail in various modes.

The system designer is warned to consider the failure modes of all component parts used in fluid power systems and to provide adequate safeguards to prevent personal injury or damage to equipment in the event of such failure.

System designers must provide a warning to end users in the system instructional manual if protection against a failure mode cannot be adequately provided.

System designers and end users are cautioned to review specific warnings found in instruction sheets packed and shipped with these products.